

Toggle Fork Terminal

Part Number	Sta-Lok Number	Wire Size	Pin Hole	A	B	C	D	Price \$
SLTF0510	150-04	5/32	5/16	1-57/64	3/4	3/8	21/64	46.03
SLTF0610	150-05-5/16	3/16	5/16	2-13/64	13/16	7/16	25/64	58.88
SLTF0612	150-05	3/16	3/8	2-13/64	13-16	7/16	25/64	58.88
SLTF0712	150-55	7/32	3/8	2-13/64	13/16	7/16	25/64	65.24
SLTF0816	150-06	1/4	1/2	2-19/32	1-3/32	5/8	33/64	70.22
SLTF0916	150-07	9/32	1/2	2-3/4	1-3/32	5/8	33/64	85.32
SLTF1016	150-08	5/16	1/2	2-27/32	1-3/32	5/8	33/64	92.94
SLTF1020	150-08-5/8	5/16	5/8	3-27/64	1-9/32	25/32	41/64	117.97
SLTF1220	150-10	3/8	5/8	3-27/64	1-9/32	25/32	41/64	142.03
SLTF1424	150-11	7/16	3/4	4-3/32	1-11/32	1	49-64	310.16
SLTF1624	150-12	1/2	3/4	4-3/32	1-11/32	1	49/64	310.16

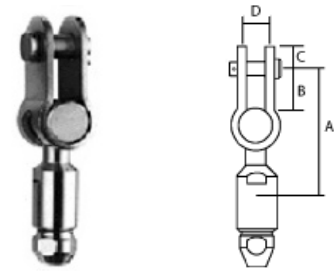

The toggle fork is useful in those cases where alignment is critical. The toggle action will reduce fatigue and help insure a fair lead from attachment point to wire. There are pin sizes available that will allow a direct replacement for the swage aircraft fixed forks. Please note that the width and the pin placement of the STA-LOK terminal may not allow close spacing in situations like double tangs for lower shrouds.

Long Toggle Fork Terminal

Part Part No.	Sta-Lok Part No.	Wire Size	Pin Hole	A	B	C	D	Price \$
SLTFL0510	179-04	5/32	5/16	3-7/8	3/4	3/8	21/64	49.02
SLTFL0612	179-05	3/16	3/8	4-3/4	13/16	7/16	25/64	63.81
SLTFL0712	179-55	7/32	3/8	4-27/32	13/16	7/16	25/64	66.08
SLTFL0816	179-06	1/4	1/2	5-17/32	1-3/32	5/8	33/64	70.97
SLTFL0916	179-07	9/32	1/2	5-27/32	1-3/32	5/8	33/64	87.07
SLTFL1016	179-08	5/16	1/2	6-17/32	1-3/32	5/8	33/64	94.18
SLTFL1020	179-08-5/8	5/16	5/8	7-13/16	1-9/32	25/32	41/64	122.72
SLTFL1220	179-10	3/8	5/8	8-13/32	1-9/32	25/32	41/64	149.88
SLTFL1424	179-11	7/16	3/4	11-3/32	1-11/32	1	49/64	320.00
SLTFL1624	179-12	1/2	3/4	11-3/32	1-11/32	1	49/64	320.00

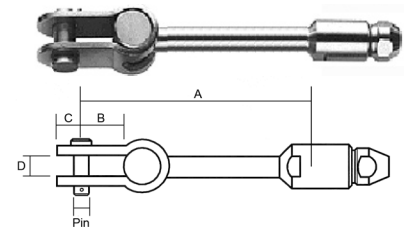

Long toggle fork is handy where a swage fork is being replaced as it allows a direct replacement without the need for adding toggles to make up for lost length. Check dimensions to insure that this replacement will fit. Check width and pin hole replacement as the replaced aircraft fork will fit in some cases where the STA-LOK toggle fork will not without some further modification to the attachment geometry.

Fork Terminal

Part Number	Sta-Lok Number	Wire Size	Pin Size	A	B	C	D	Price \$
SLFK0406	134-03	1/8	3/16	39/64	25/64	5/16	39/64	38.59
SLFK0508	134-04	5/32	1/4	27/32	19/32	23/64	1/4	45.16
SLFK0610	134-05	3/16	5/16	31/32	23/32	29/64	5/16	54.04
SLFK0714	134-55	7/32	7/16	1-3/16	7/8	5/8	13/32	74.19
SLFK0814	134-06	1/4	7/16	1-3/16	7/8	5/8	13/32	74.19
SLFK0914	134-07	9/32	7/16	1-21/64	1	5/8	13/32	84.71
SLFK1016	134-08	5/16	1/2	1-29/64	1-5/64	3/4	17/32	112.06
SLFK1220	134-10	3/8	5/8	1-5/8	1-5/32	57/64	17/32	139.01
SLFK1424	134-11	7/16	3/4	1-13/16	1-5/16	1	3/4	366.71
SLFK1624	134-12	1/2	3/4	1-13/16	1-5/16	1	3/4	366.71
SLFK1828	134-14	9/16	7/8	2-1/8	1-1/2	1-1/4	13/16	429.14
SLFK2028	134-16	5/8	7/8	2-17/64	1-37/64	1-21/64	13/16	536.53
SLFK2436	134-19	3/4	1-1/16	2-29/32	1-31/32	1-39/64	1-13/32	1,104.00
SLFK2842	134-22	7/8	1-5/16	6	2-3/8	2-1/4	1-3/8	1,304.37
SLFK3242	134-25	1	1-5/16	6	2-3/8	2-1/4	1-3/8	1,563.46

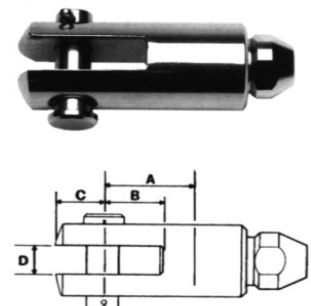

The STA-LOK fixed fork is suitable for a clean attachment to tangs and lugs where the alignment is fair.